



1-AVCW See-Thru Air Vent for Ozone Applications

For Pressures to 10 bar or Specific Gravity Down to 0,80

What Is Ozone?

Ozone is a gas that forms naturally during thunderstorms when lightning converts normal oxygen molecules (O₂) into ozone (O₃). The fresh, sweet smell in the air after a storm is the smell of ozone. The unstable ozone molecule reacts rapidly with most substances and is an extremely strong natural oxidant.

How Is Commercial Ozone Produced?

Ozone can be formed by exposing air to ultraviolet light; however, the most common method of generating ozone is by passing air through an electrical discharge. Because ozone has strong oxidizing properties, its production requires corrosion-resistant equipment.

How Is Ozone Used in Water Filtration and Purification?

Because ozone is such an effective oxidant, it kills viruses, bacteria, mold, mildew, fungus and germs. Passing ozone through water achieves high purification rates without any chemical residue. Oxygen is the only by-product.

Typical Customer Applications:

- Purifying standing ground water in Third World countries.
- Conditioning water for poultry and livestock.
- Purifying water in the bottled water industry.
- Filtering and purifying water for process applications.

A See-Thru Body Shows You It's Working

Now, you can literally see what you've been missing. The Armstrong 1-AVCW See-Thru Air Vent lets you easily check its operating condition. You won't have to waste time and money scheduling maintenance that isn't needed, and you can quickly react to a condition before it becomes a problem.

Efficient Operation

Simple ball-float mechanism doesn't need electricity to operate. The air vent automatically discharges only when air or gas is present. No liquid is lost, as with manual venting.

Positive Seating

Free-floating valve mechanism ensures positive seating and prevents liquid loss. There are no fixed pivots to wear or create friction. Wear points are heavily reinforced for long life.

Corrosion Resistance

Long-lasting PBT (polybutylene terephthalate) cap provides trouble-free operation. Stainless steel internal parts resist corrosion and reduce maintenance.

Compare – and Save the Difference

Seeing really is believing – especially when you compare the Armstrong 1-AVCW See-Thru Air Vent with manual venting. Measure the time and money you can save with a more efficient, easier-to-maintain system. For more information or technical assistance, contact your local Armstrong Representative.

Note: The Armstrong 1-AVCW should not be used in an environment where there are high levels of ketones or chlorinated or aromatic hydrocarbons.

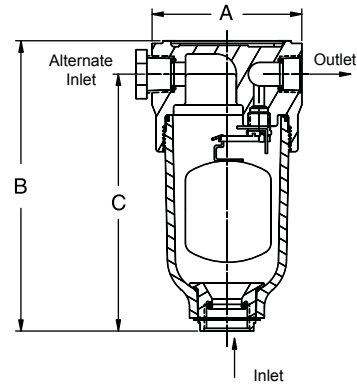

1-AVCW

Table AV-352-1. 1-AVCW List of Materials

Name of Part	Material
Cap	PBT (Polybutylene Terephthalate)
Body	Polysulfone*
O-Rings (Body Cap and Fitting)	Viton
Float Lever and Screws	Stainless Steel
Valve & Seat	Stainless Steel
Fitting	PBT (Polybutylene Terephthalate)
Retainer Ring	Zinc Plated Steel

* UV sensitive

Table AV-352-2. 1-AVCW Physical Data

	mm
Inlet Connection (In Body)	20
Inlet Connection (Alternate)	15
Outlet Connection	15
"A" Face-to-Face	89
"B" Height	172
"C" Bottom to ϕ	152
Maximum Allowable Pressure (Vessel Design)	10 bar @ 66°C
Maximum Operating Pressure	10 bar
Specific Gravity Range	1,00 to 0,80
Weight in kg (screwed)	0,5

All sizes comply with the article 3.3 of the PED (97/23/EC).

Table AV-352-3. 1-AVCW Capacity

Differential Pressure	Orifice Size	m ³ /h
bar		
1,0	1/8"	7,3
2,0		11,0
3,5		16,1
5,0		22,2
7,0		28,7
8,5		34,8
10,5		41,1

Note: Discharge of air through an orifice in m³/h at a standard atmospheric pressure of 1 bar(a) and 21°C.

All dimensions and weights are approximate. Use certified print for exact dimensions. Design and materials are subject to change without notice.