



Fixed Pivot and Snap Action Drain Traps

For Loads to 1 770 kg/h...Pressures to 69 bar

Continuous Flow or On-Off Float Type Drain Traps

Armstrong's line of fixed lever and snap action drain traps includes two basic models available in cast iron and forged steel. The floats are light enough to handle light liquids.

No. 21 – A small, high-quality, economical drain trap for use on drainage jobs where dirt and oil are not encountered. It employs a single lever with a fixed pivot.

No. 21-312 – Forged steel version of the No. 21 with larger float and higher leverage.

No. 71-A – Wide open, tight-shut drain trap for use where fine dirt and grit may be present or where liquid load is light. A flat spring in the leverage system holds the valve closed until the trap body is nearly full of water. Then it snaps open, washing dirt through. When the trap body is nearly empty, the spring snaps the valve shut.

No. 71-315 – Forged steel version of No. 71-A.

Caution: Ball float drain traps are not recommended where heavy oil, sludge or considerable dirt are encountered in lines. Under these circumstances use Armstrong inverted bucket BVSU traps.

Table LD-398-1. Maximum Operating Pressures in bar for Handling Different Specific Gravity With Orifices Available in Fixed Lever and Snap Action Drain Traps

(See pages LD-380 and LD-381)

Model No.	Sp. Grav.	1,00	0,95	0,90	0,85	0,80	0,75	0,70	0,65	0,60	0,55	0,50	
		Maximum Operating Pressure in bar @ 38°C											
	Orifice Size (in)	bar	bar	bar	bar	bar	bar	bar	bar	bar	bar	bar	
21	1/4"	1,5	1,4	1,3	1,1	1,0	0,9	0,8	0,7	0,5	0,4	0,3	
	7/32"	1,9	1,8	1,6	1,5	1,0	1,2	1,0	0,9	0,7	0,6	0,4	
	3/16"	2,6	2,4	2,2	2,0	1,8	1,6	1,4	1,2	1,0	0,7	0,5	
	5/32"	3,8	3,5	3,2	2,9	2,6	2,3	2,0	1,7	1,4	1,1	0,8	
	9/64"	4,6	4,2	3,9	3,5	3,1	2,8	2,4	2,1	1,7	1,3	1,0	
	1/8"	5,8	5,4	4,9	4,4	4,0	3,5	3,0	2,6	2,1	1,7	1,2	
	3/32"	10,2	9,4	8,6	7,7	6,9	6,1	5,3	4,5	3,7	2,9	2,1	
	5/64"	14,0	13,0	12,0	11,0	9,9	8,7	7,6	6,4	5,3	4,1	3,0	
1/16"	17,0	17,0	17,0	17,0	15,0	13,0	12,0	9,9	8,1	6,3	4,6		
21-312*	96 g Float	1/4"	2,9	2,7	2,5	2,3	2,1	1,9	1,7	1,5	1,3	1,1	0,9
		7/32"	3,8	3,5	3,2	3,0	2,7	2,5	2,2	2,0	1,7	1,5	1,2
		3/16"	5,1	4,7	4,4	4,0	3,7	3,4	3,0	2,7	2,3	2,0	1,6
		5/32"	14,0	14,0	13,0	12,0	10,6	9,6	8,6	7,6	6,6	5,6	4,6
	128 g Float	9/64"	16,0	15,0	14,0	14,0	13,0	12,0	10,6	9,4	8,1	6,9	5,7
		1/8"	20,0	18,0	17,0	15,0	14,0	14,0	13,0	12,0	10,2	8,7	7,2
		3/32"	34,0	32,0	29,0	27,0	24,0	21,0	19,0	16,0	14,0	14,0	13,0
	170 g Float	5/64"	41,0	37,0	34,0	34,0	34,0	30,0	27,0	23,0	19,0	15,0	14,0
		1/16"	41,0	41,0	41,0	41,0	39,0	34,0	34,0	34,0	29,0	23,0	17,0
71-A & 71-315	1/4"	0,7	0,7	0,7	0,7	**	**	**	**	—	—	—	
	3/16"	1,4	1,4	1,4	1,4	**	**	**	**	—	—	—	
	1/8"	6,9	6,9	6,9	6,9	**	**	**	**	—	—	—	
	7/64"	14,0	14,0	14,0	14,0	**	**	**	**	—	—	—	
71-A	5/64"	17,0	17,0	17,0	17,0	—	—	—	—	—	—	—	
71-315	5/64"	35,0	35,0	35,0	35,0	—	—	—	—	—	—	—	
	1/16"	69,0	69,0	69,0	69,0	—	—	—	—	—	—	—	

Note: If actual specific gravity falls between those shown in above table, use next lower. For example, if actual gravity is 0,73, use 0,70 gravity data.

* 5/32" orifice (and smaller) utilizes higher leverage mechanism designated 21-312V.

** For applications on liquids of specific gravity 0,65 to 0,85, consult factory.

Fixed Pivot and Snap Action Drain Traps

For Loads to 1 770 kg/h...Pressures to 69 bar



Model No.	Cast Iron		Forged Steel	
	21 †	71-A*	21-312 †	71-315*
Pipe Connections	15 – 20	20 – 25	15 – 20 – 25	20 – 25 – 32 – 40
"A"	157	216	171	248
"B"	133	273	259	381
"BB" (PN100**)	—	—	300 – 305 – 313	433 – 433 – 437
"D"	—	108	141	198
"K"	33	—	32	—
"L"	—	89	86	117
"LL" (PN100**)	—	—	127 – 132 – 140	169 – 169 – 173
Weight in kg (screwed & SW)	4	13	14	42
Weight in kg (flanged PN100**)	—	—	15,8 – 17,8 – 18,8	43,5 – 46,5 – 48,8
Maximum Allowable Pressure (Vessel Design)††	17 bar @ 232°C		41 bar @ 38°C 34 bar @ 400°C	69 bar @ 38°C 41 bar @ 400°C

† Cast 316 stainless steel body and cap with all stainless steel internals available. Aluminum body and cap available for Model 21 only. Consult factory.

†† May be derated depending on flange rating and type.

* Snap action drain traps **should not** be used where load exceeds 54 kg/h. Use on greater loads shortens spring life.

** Other flange sizes, ratings and face-to-face dimensions are available on request.

All models comply with the article 3.3 of the PED (97/23/EC).

Table LD-399-2. 21-LD and 71-LD List of Materials					
Model No.	Valve & Seat	Leverage System	Float	Body & Cap	Gasket
21	Stainless Steel			Cast Iron	Compressed Asbestos-free
71-A				ASTM A48 Class 30	
21-312 71-315				Forged Steel* ASTM A105	

* Model 71-315 cap is cast steel.

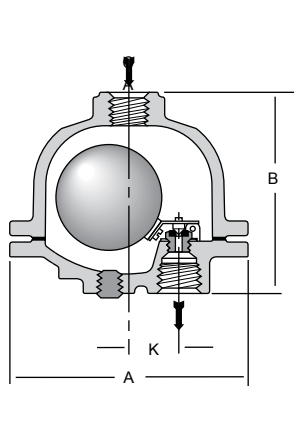
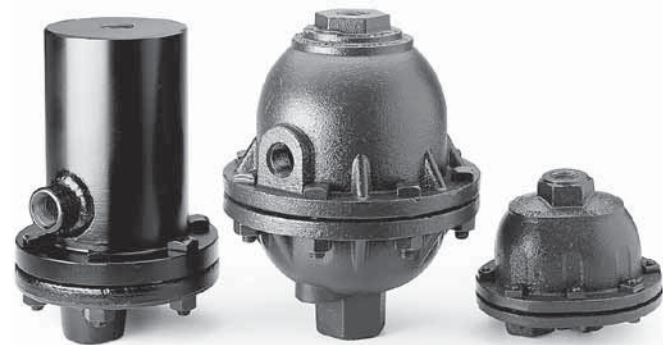

Figure LD-399-1.
Model 21 cast iron fixed lever drain trap.

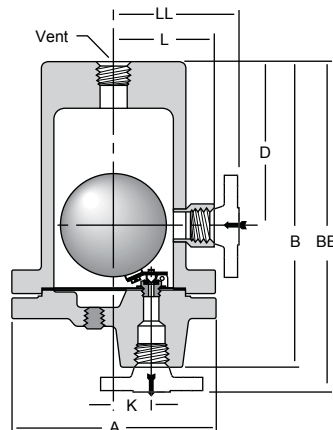

Figure LD-399-2.
Model 21-312 forged steel fixed lever drain trap.

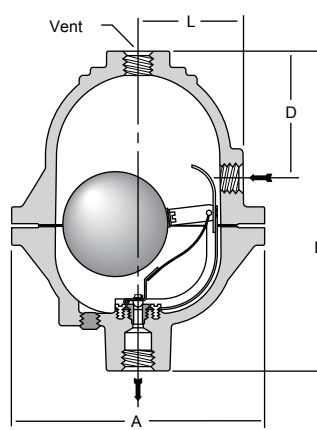

Figure LD-399-3.
Model 71-A cast iron snap action drain trap.

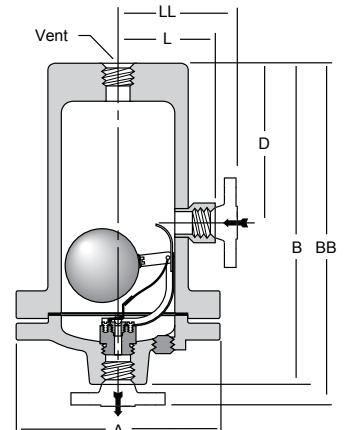

Figure LD-399-4.
Model 71-315 forged steel snap action drain trap.

Liquid Drainers

All dimensions and weights are approximate. Use certified print for exact dimensions. Design and materials are subject to change without notice.