



Free Floating Lever Drain Traps

For Loads to 22 700 kg/h...Pressures to 69 bar

Table LD-392-1. Max. Oper. Press. in bar for Handling Different Specific Gravity Liquids With Orifices Available in Guided Free Floating Lever Drain Traps (See pg. LD-380 and LD-381)

Model No.	Sp. Grav. Orifice (in)	1,00	0,95	0,90	0,85	0,80	0,75	0,70	0,65	0,60	0,55	0,50	
		Maximum Operating Pressure in bar											
		bar	bar	bar	bar	bar	bar	bar	bar	bar	bar	bar	
1-LD	1/8"	8,3	7,6	6,8	6,0	5,2	4,4	3,6	2,8	2,0	1,2	0,4	
	7/64"	9,9	9,0	8,0	7,1	6,1	5,2	4,3	3,3	2,4	1,4	0,5	
	#38	12,5	11,0	10,2	9,0	7,8	6,6	5,4	4,2	3,0	1,8	0,6	
	5/64"	20,7	19,9	17,8	15,7	13,7	11,6	9,5	7,4	5,3	3,2	1,1	
11-LD	1/8"	12,1	11,1	10,1	9,0	7,9	6,9	5,8	4,8	3,7	2,7	1,6	
	7/64"	14,0	13,0	12,0	10,7	9,4	8,2	6,9	5,7	4,4	3,2	1,9	
	#38	18,0	17,0	15,0	14,0	12,0	10,4	8,8	7,2	5,6	4,0	2,5	
	5/64"	28,0	28,0	27,0	24,0	21,0	18,0	15,0	13,0	9,9	7,1	4,3	
2-LD to 17 bar 22-LD to 37 bar	5/16"	1,5	1,4	1,3	1,1	1,0	0,9	0,8	0,7	0,5	0,4	0,3	
	1/4"	2,5	2,3	2,1	1,9	1,7	1,5	1,3	1,1	0,9	0,7	0,5	
	3/16"	5,5	5,0	4,6	4,2	3,7	3,3	2,8	2,4	2,0	1,5	1,1	
	5/32"	9,4	8,7	7,9	7,2	6,4	5,6	4,9	4,1	3,4	2,6	1,8	
	1/8"	16,1	14,8	13,5	12,2	10,9	9,6	8,4	7,1	5,8	4,5	3,2	
	7/64"	20,6	19,0	17,3	15,7	14,0	12,0	10,7	9,0	7,4	5,7	4,0	
	#38	25,7	23,6	21,6	19,5	17,4	15,0	13,0	11,2	9,2	7,1	5,0	
	5/64"	37,0	33,0	32,0	29,0	26,0	23,0	20,0	17,0	14,0	10,5	7,4	
32-LD	5/16"	2,0	1,8	1,6	1,4	1,2	1,0	0,9	0,7	0,5	0,3	0,1	
	1/4"	3,3	3,0	2,6	2,3	2,0	1,7	1,4	1,1	0,8	0,5	0,2	
	3/16"	7,2	6,5	5,8	5,2	4,5	3,8	3,1	2,4	1,8	1,1	0,4	
	5/32"	12,0	11,0	10,0	8,9	7,7	6,5	5,4	4,2	3,0	1,9	0,7	
	1/8"	21,0	19,0	17,0	15,0	13,0	11,0	9,0	7,2	5,2	3,2	1,2	
	7/64"	27,0	25,0	22,0	19,0	17,0	14,0	12,0	9,0	6,6	4,1	1,5	
	#38	34,0	31,0	27,0	24,0	21,0	18,0	15,0	11,0	8,0	5,1	1,9	
	5/64"	41,0	41,0	40,0	36,0	31,0	26,0	22,0	17,0	12,0	7,0	2,8	
3-LD to 17 bar (Cast Iron) 13-LD to 39 bar (Stainless) 33-LD to 62 bar (Steel)	1/2"	1,1	1,0	0,9	0,8	0,7	0,6	0,5	0,4	0,3	0,2	0,1	
	3/8"	2,3	2,1	1,9	1,7	1,5	1,3	1,1	0,9	0,7	0,5	0,3	
	5/16"	3,7	3,4	3,0	2,7	2,4	2,1	1,7	1,4	1,1	0,8	0,4	
	9/32"	4,9	4,5	4,0	3,6	3,2	2,7	2,3	1,9	1,4	1,0	0,6	
	1/4"	7,4	6,7	6,1	5,4	4,8	4,1	3,5	2,8	2,2	1,5	0,9	
	7/32"	10,5	9,6	8,7	7,7	6,8	5,9	5,0	4,0	3,1	2,2	1,2	
	3/16"	16,0	14,0	13,0	12,0	10,3	8,9	7,5	6,1	4,7	3,3	1,9	
	5/32"	25,0	23,0	20,0	18,0	16,0	14,0	12,0	9,5	7,3	5,1	2,9	
	1/8"	50,0	46,0	41,0	37,0	32,0	28,0	24,0	19,0	15,0	10,3	5,9	
	7/64"	62,0	58,0	53,0	47,0	41,0	36,0	30,0	25,0	19,0	13,0	7,6	
	6-LD Cast Iron	1 1/16"	1,4	1,3	1,2	1,1	1,0	0,9	0,8	0,7	0,6	0,5	0,4
		7/8"	2,2	2,1	1,9	1,8	1,6	1,4	1,3	1,1	1,0	0,8	0,6
3/4"		3,2	3,0	2,8	2,5	2,3	2,1	1,9	1,6	1,4	1,2	0,9	
5/8"		4,9	4,6	4,2	3,9	3,5	3,2	2,8	2,5	2,1	1,8	1,4	
9/16"		6,5	6,1	5,6	5,2	4,7	4,2	3,8	3,3	2,8	2,4	1,9	
1/2"		9,5	8,8	8,1	7,5	6,8	6,1	5,4	4,8	4,1	3,4	2,8	
7/16"		13,0	13,0	12,0	11,0	10,0	8,7	7,7	6,8	5,8	4,9	3,9	
3/8"		17,0	17,0	17,0	17,0	15,0	14,0	12,0	11,0	9,0	7,7	6,2	
11/32"		17,0	17,0	17,0	17,0	17,0	17,0	16,0	14,0	12,0	10,0	8,2	
5/16"		17,0	17,0	17,0	17,0	17,0	17,0	17,0	17,0	17,0	16,0	13,0	
9/32"		17,0	17,0	17,0	17,0	17,0	17,0	17,0	17,0	17,0	17,0	14,0	
1/4"		17,0	17,0	17,0	17,0	17,0	17,0	17,0	17,0	17,0	17,0	17,0	
7/32"		17,0	17,0	17,0	17,0	17,0	17,0	17,0	17,0	17,0	17,0	17,0	
3/16"		17,0	17,0	17,0	17,0	17,0	17,0	17,0	17,0	17,0	17,0	17,0	
36-LD Forged Steel	1 1/16"	1,1	1,0	0,9	0,8	0,7	0,6	0,5	0,4	0,3	0,2	0,1	
	7/8"	1,7	1,6	1,4	1,3	1,1	0,95	0,79	0,63	0,47	0,31	0,16	
	3/4"	2,5	2,3	2,1	1,8	1,6	1,4	1,1	0,91	0,68	0,45	0,22	
	5/8"	3,9	3,5	3,1	2,8	2,4	2,1	1,7	1,4	1,05	0,69	0,34	
	9/16"	5,1	4,6	4,2	3,7	3,2	2,8	2,3	1,8	1,4	0,92	0,46	
	1/2"	7,4	6,7	6,0	5,4	4,7	4,0	3,4	2,7	2,0	1,3	0,66	
	7/16"	10,5	9,6	8,6	7,6	6,7	5,7	4,8	3,8	2,9	1,9	0,94	
	3/8"	17,0	15,0	14,0	12,0	10,5	9,0	7,5	6,0	4,5	3,0	1,5	
	11/32"	22,0	20,0	18,0	16,0	14,0	12,0	10,0	8,0	6,0	4,0	2,0	
	5/16"	28,0	26,0	23,0	21,0	18,0	15,0	13,0	10,3	7,7	5,1	2,5	
	9/32"	37,0	34,0	30,0	27,0	24,0	20,0	17,0	13,0	10,1	6,7	3,3	
	1/4"	54,0	49,0	44,0	39,0	35,0	30,0	25,0	20,0	15,0	9,8	4,9	
	7/32"	69,0	69,0	63,0	56,0	49,0	42,0	35,0	28,0	21,0	14,0	6,9	
	3/16"	69,0	69,0	69,0	69,0	69,0	69,0	68,0	57,0	46,0	34,0	23,0	
Specific Gravity		1,00	0,95	0,90	0,85	0,80	0,75	0,70	0,65	0,60	0,55	0,50	

Note: If specific gravity falls between those shown in the chart, use the next lower gravity. For example, if specific gravity is 0,73, use 0,70 gravity data.

<p>High Temperature Service Maximum allowable working pressures of floats decrease at temperatures above 37,8°C. Allow for approximately:</p> <ul style="list-style-type: none"> • 10% decrease at 93,3°C • 15% decrease at 148,9°C • 20% decrease at 204,4°C 	<p>The float is not always the limiting factor, however. Consult with Armstrong Application Engineering if you have a high-temperature application that also requires maximum operating pressures.</p>
---	--

Free Floating Guided Lever Drain Traps

For Loads to 22 300 kg/h...Pressures to 21 bar



Armstrong's cast iron, free-floating guided lever drain traps use the same bodies, caps, lever mechanisms, valves and seats of Armstrong inverted bucket steam traps that have been proven in years of service. Elliptical floats and high leverage make it possible to open large orifices to provide adequate capacity for drain trap size and weight.

The hemispherical valve, seat and leverage of the 1-LD, 2-LD, 3-LD and 6-LD cast iron traps are identical in design, materials and workmanship to those for saturated steam service up to 21 bar with the exception of the addition of a guidepost to assure a positive, leaktight valve closing under all conditions.

Model No.	Valve & Seat	Leverage System	Float	Body & Cap	Gasket
1-LD 2-LD 3-LD 6-LD	Stainless Steel			Cast Iron ASTM A48 Class 30	Compressed Asbestos-free

For information on special materials, consult the Armstrong Application Engineering Department.

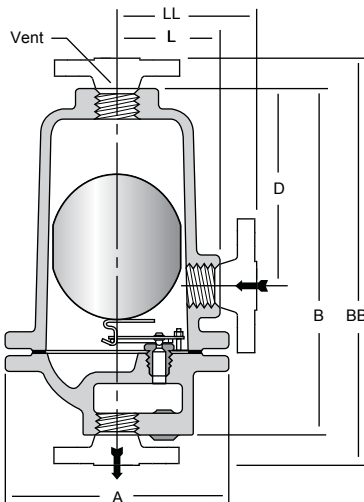

Figure LD-393-1.

Models 2-LD, 3-LD and 6-LD cast iron guided lever drain traps. Model 1-LD has standard top inlet and optional side connection.



Model No.	Cast Iron			
	1-LD	2-LD	3-LD	6-LD
Pipe Connections	15*	15 – 20	15 – 20 – 25	40 – 50
"A"	95	133	162	259
"B"	140	203	273	432
"BB" (PN40**)	N/A	320 – 330	400 – 392	562 – 568
"D"	73	111	155	213
"K" (Q Outlet to Q Inlet)	21	—	—	—
"L"	48	62	73	123
"LL" (PN40**)	N/A	179 – 189	142 – 134	180 – 186
Weight in kg (screwed)	1,8	6	10	36
Weight in kg (flanged PN40**)	N/A	8,7 – 9,6	13,6 – 14,2	42,6 – 45,0
Maximum Allowable Pressure (Vessel Design)††	21 bar @ 93°C		17 bar @ 232°C	

Note: Vessel design pressure may exceed float collapse pressure in some cases.

Pipe size of vent connection is same as that of inlet and outlet connections.

* 1/4" outlet.

** Other flange sizes, ratings and face-to-face dimensions are available on request.

† For pressures not exceeding 17 bar, a maximum temperature of 232°C is allowed.

†† May be derated depending on flange rating and type.

Shade indicates products that are CE Marked according to the PED (97/23/EC). All the other models comply with the Article 3.3 of the same directive.

All dimensions and weights are approximate. Use certified print for exact dimensions. Design and materials are subject to change without notice.



Free Floating Guided Lever Drain Traps

For Loads to 4 300 kg/h...Pressures to 39 bar

Armstrong's stainless steel, free-floating guided lever drain traps use the same bodies, caps, lever mechanisms, valves and seats of Armstrong inverted bucket steam traps that have been proven in years of service. Elliptical floats and high leverage make it possible to open large orifices to provide adequate capacity for drain trap size and weight.

The hemispherical valve, seat and leverage of the 11-LD, 22-LD and 13-LD stainless steel traps are identical in design, materials and workmanship to those for saturated steam service up to 39 bar with the exception of the addition of a guidepost to assure a positive, leaktight valve closing under all conditions.

Table LD-394-1. 10-LD List of Materials					
Model No.	Valve & Seat	Leverage System	Float	Body & Cap	Gasket
11-LD 22-LD 13-LD	Stainless Steel			Sealed Stainless Steel, 304L	—

For information on special materials, consult the Armstrong Application Engineering Department.

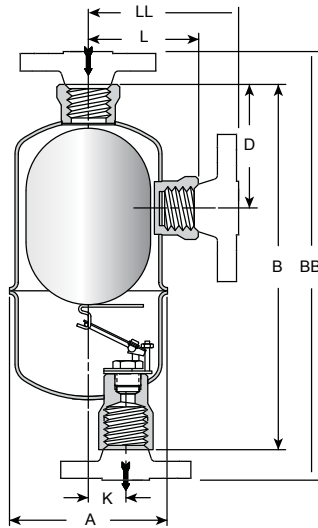

Figure LD-394-1.

Models 11-LD, 22-LD and 13-LD stainless steel guided lever liquid drain trap with sealed, tamperproof construction.



Table LD-394-2. 10-LD Physical Data (dimensions in mm)			
Model No.	Stainless Steel		
	11-LD**	22-LD	13-LD
Pipe Connections	20*	20	25
"A"	70	100	114
"B"	183	221	289
"BB" (PN40***)	228 – 232	271	375
"D"	—	83	156
"K"	14	22	30
"L"	—	67	83
"LL" (PN40***)	—	117	126
Weight in kg (screwed & SW)	0,8	2,3	3,4
Weight in kg (flanged PN40***)	2,9 – 4,0	5,2	7,3
Maximum Allowable Pressure (Vessel Design)†	34 bar @ 38°C 30 bar @ 260°C	41 bar @ 38°C 33 bar @ 260°C	39 bar @ 38°C 34 bar @ 260°C

Note: Vessel design pressure may exceed float collapse pressure in some cases.

Pipe size of vent connection is same as that of inlet and outlet connections.

* 1/2" outlet.

** No side connection

*** Standard flanges are in carbon steel, stainless steel flanges are optional. Other flange sizes, ratings and face-to-face dimensions are available on request. Shade indicates products that are CE Marked according to the PED (97/23/EC). All the other models comply with the Article 3.3 of the same directive.

† May be derated depending on flange rating and type.

All dimensions and weights are approximate. Use certified print for exact dimensions. Design and materials are subject to change without notice.

Armstrong International SA • Parc Industriel des Hauts-Sarts (2^e Avenue) • 4040 Herstal • Belgium

Tel.: +32 (0)4 240 90 90 • Fax: +32 (0)4 240 40 33

www.armstronginternational.eu • info@armstronginternational.eu