



# Free Floating Lever Dual Gravity Drain Traps

For Pressures to 69 bar

Armstrong free floating lever dual gravity drain traps are identical to the units described on pages LD-393 and LD-469 except float weights are modified to make them suitable for draining water from a light liquid. If you wish to use them for draining any liquid with specific gravity other than 1,00, consult the Armstrong Application Engineering Department.

Floats for dual gravity drain traps are weighted with quenching oil which, in the unlikely possibility of float failure, may be dispersed through the system. If this is a hazard, consult the Armstrong Application Engineering Department.

**Note:** Armstrong can design dual gravity traps for venting light liquids from above heavier liquids. Consult the Armstrong Application Engineering Department.

### Viscosity Considerations for Dual Gravity Traps

The operation of dual gravity traps depends upon a float that will sink in the light liquid and float in the heavy liquid. When the specific gravities of the two liquids are very close, the available operating forces are, therefore, also very small. Viscous fluids may impair the ability of the trap to respond to changing liquid levels.

Consult Armstrong's Application Engineering Department if your application involves fluids more viscous than 70 cs, which is approximately the viscosity of a light machine oil.

**Table LD-402-2. Maximum Operating Pressures in bar for Draining Water From Different Specific Gravity Liquids With Orifices Available in Dual Gravity Drain Traps (See pages LD-380 and LD-381)**

Model No.	Sp. Grav.	0,50	0,55	0,60	0,65	0,70	0,75	0,80	0,85	
	Float Wt, g	170	184	199	213	228	242	257	271	
2-DG	Orifice (in)	Maximum Operating Pressure in bar								
	5/16"	1,0	0,9	0,7	0,6	0,5	0,35	—	—	
	1/4"	1,6	1,4	1,2	1,0	0,8	0,6	0,4	—	
	3/16"	3,6	3,0	2,6	2,2	1,8	1,4	0,9	0,45	
	5/32"	6,0	5,5	4,6	3,8	3,0	2,4	1,6	0,8	
	1/8"	10,0	9,0	8,0	6,5	5,0	4,0	2,6	1,4	
	7/64"	13,0	12,0	10,0	8,5	6,5	5,0	3,4	1,8	
32-DG	Sp. Grav.	0,50	0,55	0,60	0,65	0,70	0,75	0,80	0,85	
	Float Wt, g	248	271	293	315	338	360	382	405	
	Orifice (in)	Maximum Operating Pressure in bar								
	5/16"	1,6	1,4	1,2	1,0	0,9	0,7	0,5	—	
	1/4"	2,6	2,4	2,0	1,8	1,4	1,2	0,8	0,5	
	3/16"	6,0	5,0	4,6	3,8	3,2	2,6	1,8	1,2	
	5/32"	10,0	9,0	8,0	6,5	5,5	4,4	3,2	2,0	
3-DG to 17 bar* Cast Iron  33-DG for all pressures	Sp. Grav.	0,50	0,55	0,60	0,65	0,70	0,75	0,80	0,85	0,90
	Float Wt, g	317	345	373	401	430	458	486	514	542
	Orifice (in)	Maximum Operating Pressure in bar								
	1/2"	0,8	0,7	0,6	0,5	0,45	0,35	—	—	—
	3/8"	1,8	1,6	1,4	1,2	0,9	0,7	0,5	—	—
	5/16"	2,8	2,4	2,2	1,8	1,4	1,2	0,8	0,5	—
	9/32"	3,6	3,2	2,8	2,4	2,0	1,6	1,0	0,6	—
	1/4"	5,5	4,8	4,2	3,6	3,0	2,2	1,6	1,0	—
	7/32"	8,0	7,0	6,0	5,0	4,2	3,2	2,4	1,4	0,45
	3/16"	12,0	10,0	9,0	7,5	6,5	4,8	3,4	2,0	0,7
	5/32"	19,0	16,0	14,0	12,0	10,0	7,5	5,5	3,2	1,0
1/8"	38,0	34,0	28,0	24,0	20,0	15,0	11,0	6,5	2,2	
7/64"	48,0	42,0	36,0	32,0	26,0	20,0	14,0	8,5	2,8	
6-DG to 17 bar* Cast Iron  36-DG to 69 bar Steel	Sp. Grav.	0,50	0,55	0,60	0,65	0,70	0,75	0,80	0,85	0,90
	Float Wt, g	1 483	1 622	1 760	1 899	2 038	2 177	2 316	2 455	2 594
	Orifice (in)	Maximum Operating Pressure in bar								
	1 1/6"	0,9	0,8	0,7	0,6	0,5	0,4	—	—	—
	7/8"	1,4	1,2	1,2	1,0	0,8	0,7	0,5	0,35	—
	3/4"	2,2	1,8	1,6	1,4	1,2	1,0	0,7	0,5	—
	5/8"	3,2	2,8	2,6	2,2	1,8	1,4	1,2	0,8	0,4
	9/16"	4,2	3,8	3,4	2,8	2,4	2,0	1,4	1,0	0,5
	1/2"	6,0	5,5	4,8	4,2	3,4	2,8	2,2	1,4	0,8
	7/16"	9,0	8,0	7,0	6,0	5,0	4,0	3,0	2,0	1,2
	3/8"	14,0	12,0	11,0	9,5	8,0	6,5	4,8	3,2	1,8
	11/32"	18,0	16,0	14,0	12,0	10,0	8,5	6,5	4,4	2,4
	5/16"	24,0	22,0	19,0	16,0	13,0	11,0	8,0	5,5	3,0
	9/32"	32,0	28,0	24,0	20,0	18,0	14,0	11,0	7,5	4,0
	1/4"	46,0	40,0	36,0	30,0	26,0	20,0	16,0	11,0	6,0
7/32"	65,0	55,0	50,0	44,0	36,0	30,0	22,0	15,0	8,5	
3/16"	69,0	69,0	69,0	69,0	60,0	48,0	36,0	24,0	14,0	

**Note:** If actual specific gravity falls between those shown in the above table, use the next higher gravity. For example, if actual gravity is 0,73, use 0,75 gravity data.  
\* For vessel pressures above 17 bar, always use steel drain traps.

# Free Floating Lever Dual Gravity Drain Traps

For Pressures to 69 bar



Table LD-403-1. DG Series List of Materials					
Model No.	Valve & Seat	Leverage System	Float	Body & Cap	Gasket
2-DG 3-DG 6-DG	Stainless Steel			Cast Iron ASTM A48 Class 30	Compressed Asbestos-free
32-DG 33-DG 36-DG				Forged Steel ASTM A105	

For information on special materials, consult the Armstrong Application Engineering Department.

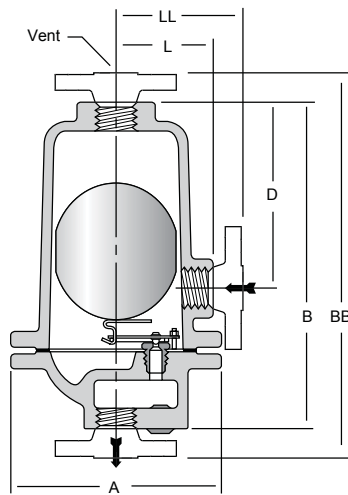

**Figure LD-403-1.**

Models 2-DG, 3-DG and 6-DG cast iron dual gravity drain traps.

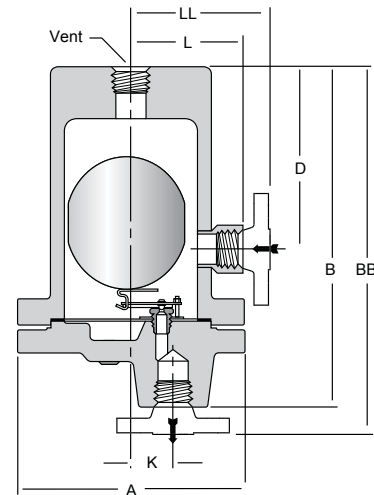

**Figure LD-403-2.**

Models 32-DG, 33-DG and 36-DG Forged steel dual gravity drain traps. Socketweld or flanged connections are also available.

Table LD-403-2. DG Series Physical Data in mm						
Model No.	Cast Iron			Forged Steel		
	2-DG	3-DG	6-DG	32-DG*	33-DG*	36-DG*
Pipe Connections	15 – 20	15 – 20 – 25	40 – 50	15 – 20 – 25	15 – 20 – 25	40 – 50
"A"	133	161	259	171	203	302
"B"	203	273	432	259	295	435
"BB" (PN40 - PN100**)	320 – 330	400 – 392	562 – 568	300 – 305	343 – 349 – 355	500 – 505
"D"	111	155	213	141	154	229
"K"	—	—	—	32	37	54
"LL" (PN40 - PN100**)	179 – 189	203 – 195	180 – 186	127 – 132	145 – 153 – 159	198 – 204
"B"	203	273	432	259	295	435
Weight in kg (screwed & SW)	6	10	36	14	22	74
Weight in kg (flanged PN40 - PN100**)	8,7 – 9,6	13,6 – 14,2	42,6 – 45,0	15,8 – 17,8	25,0 – 26,0	83,2 – 87,2
Maximum Allowable Pressure (Vessel Design)†	17 bar @ 232°C		17 bar @ 232°C	41 bar @ 38°C 35 bar @ 400°C	69 bar @ 38°C 41 bar @ 400°C	

\* Available in Type 316 stainless steel. Consult factory.

\*\* Other flange sizes, ratings and face-to-face dimensions are available on request.

Shade indicates products that are CE Marked according to the PED (97/23/EC). All the other models comply with the Article 3.3 of the same directive.

† May be derated depending on flange rating and type.

**All dimensions and weights are approximate. Use certified print for exact dimensions. Design and materials are subject to change without notice.**