



Inverted Bucket Drain Traps (BVSW Model)

For Loads to 3 200 kg/h...Pressures to 45 bar

Armstrong inverted bucket drain traps are designed for systems where heavy oil and dirt may be encountered. The enlarged bucket vent equipped with a scrub wire (BVSW) allows free flow through the bucket vent and discharge through the orifice located in the top of the trap.



BVSW Model No.	Body & Cap	Valve & Seat	Bucket & Leverage System	Gasket
800, 811, 812, 813, 880, 881, 882, 883, 211, 212, 213	Cast Iron ASTM A48 Class 30	Stainless Steel	Titanium V&S (pressures higher than 38 bar)	Compressed Asbestos-free
312, 313	Forged Steel ASTM A105			
981, 983	Cast Steel ASTM A216 Grade WCB			

Model No.	800 BVSW 880 BVSW	811 BVSW 881 BVSW 211 BVSW	812 BVSW 882 BVSW 212 BVSW	312 BVSW*	813 BVSW 883 BVSW 213 BVSW 313 BVSW* 983 BVSW*	981 BVSW*
Orifice Size	bar	bar	bar	bar	bar	bar
1/4"	—	—	—	—	8,5	—
7/32"	—	—	—	—	12,5	—
3/16"	—	—	—	—	17,0	3,5
5/32"	—	—	8,5	—	31,0	6,0
1/8"	5,5	8,5	14,0	—	41,0	11,0
7/64"	8,5	14,0	17,0	41,0	—	17,0
#38	10,5	17,0	—	—	—	22,5

Note: Larger capacity models available. Consult your local Armstrong Representative or the Armstrong factory.
* Use steel traps for pressures above 17 bar.

Model No.	800 BVSW	811 BVSW	812 BVSW	813 BVSW
Pipe Connections	15 – 20	15 – 20 – 25	15 – 20	20 – 25
Test Plug	1/4"	1/4"	1/2"	3/4"
"A"	95	95	143	178
"B"	138	175	230	298
"C"	127	127	165	197
"CC" "Face-to-Face (flanged PN40*)	195 – 191	195 – 191 – 197	233 – 229	261
"D"	70	108	137	179
Number of Bolts	6	6	6	6
Weight in kg (screwed)	2,3	2,7	6,8	12,5
Weight in kg (flanged PN40*)	3,6 – 4,3	4,1 – 4,3 – 4,8	8,2 – 9,0	14,3 – 14,8
Maximum Allowable Pressure (Vessel Design)†	17 bar @ 232°C			
Maximum Operating Pressure	10,5 bar	17,0 bar		

Note: Larger capacity models available. Consult your local Armstrong Representative or the Armstrong factory.
* Other flange sizes, ratings and face-to-face dimensions are available on request.
All models comply with the article 3.3 of the PED (97/23/EC).
† May be derated depending on flange rating and type.

All dimensions and weights are approximate. Use certified print for exact dimensions. Design and materials are subject to change without notice.

Inverted Bucket Drain Traps (BVSW Model)

For Loads to 3 200 kg/h...Pressures to 45 bar



Model No.	Cast Iron				Cast Steel	
	880 BVSW	881 - 881F BVSW	882 BVSW	883 BVSW	981 BVSW	983 BVSW
Pipe Connections	15 - 20	15 - 20 - 25	15 - 20	20 - 25 - 32	15 - 20	20 - 25
Test Plug	1/4"	1/4"	1/2"	3/4"	1/2"	3/4"
"A"	95	95	143	178	114	184
"B"	154	179	244	314	219	313
"C"	127	127	165	200	137	197
"CC" "Face-to-Face (flanged PN40 - 881F PN16*)"	195 - 191	150 - 150 - 160	233 - 229	264 - 264 - 326	196 - 194	282
"D"	87	113	146	187	122	193
Number of Bolts	6	6	6	6	6	6
Weight in kg (screwed & SW)	2,5	2,7	7,0	14,1	5,2	19,5
Weight in kg (flanged PN40 - 881F PN16*)	4,0 - 4,6	3,8 - 4,2 - 4,6	8,8 - 9,4	15,6 - 16,1 - 17,7	7,0	26,0
Maximum Allowable Pressure (Vessel Design)	17 bar @ 232°C				41 bar @ 343°C	41 bar @ 343°C
Maximum Operating Pressure	10,5 bar	17,0 bar			22,5 bar	41,0 bar

Note: Larger capacity models available. Consult your local Armstrong Representative or the Armstrong factory.

* Other flange sizes, ratings and face-to-face dimensions are available on request.

Shade indicates products that are CE Marked according to the PED (97/23/EC). All the other models comply with the Article 3.3 of the same directive.

Model No.	Cast Iron			Forged Steel	
	211 BVSW	212 BVSW	213 BVSW	312 BVSW	313 BVSW
Pipe Connections	15	15 - 20	15 - 20 - 25	15 - 20 - 25	15 - 20 - 25
Test Plug	1/8"	3/8"	1/2"	—	—
"A"	108	133	162	171	203
"B"	162	203	273	259	295
"BB" Face-to-Face (flanged PN40 - PN100*)	282	320 - 330	390 - 400 - 392	307 - 314 - 320	343 - 349 - 355
"G"	—	—	—	121	130
"K" (Q Outlet to Q Inlet)	—	—	—	31,7	36,5
Number of Bolts	6	8	6	6	8
Weight in kg (screwed & SW)	2,7	5,2	9,2	13,6	22,0
Weight in kg (flanged PN40 - PN100*)	4,1	7,0 - 7,6	11 - 11,6 - 12	14,5 - 15,5 - 16	22,5 - 23,5 - 24
Maximum Allowable Pressure (Vessel Design)	17 bar @ 232°C			41 bar @ 343°C	75 bar @ 343°C
Maximum Operating Pressure	17,0 bar			41,0 bar	45,0 bar

Note: Larger capacity models available. Consult your local Armstrong Representative or the Armstrong factory.

* Other flange sizes, ratings and face-to-face dimensions are available on request.

Shade indicates products that are CE Marked according to the PED (97/23/EC). All the other models comply with the Article 3.3 of the same directive.

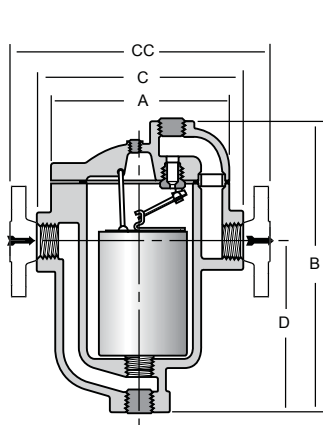

Figure LD-391-1.
Series 800

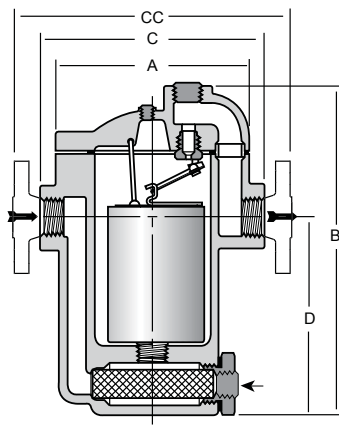

Figure LD-391-2.
Series 880 & 980

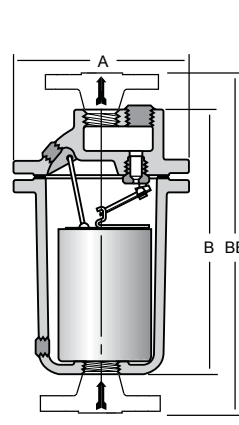

Figure LD-391-3.
Series 200

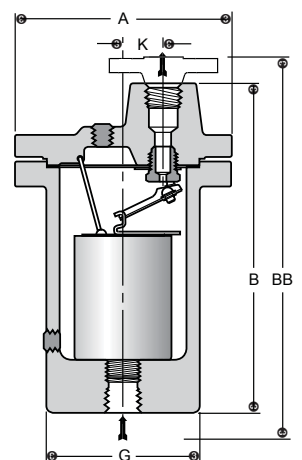

Figure LD-391-4.
Series 300

Liquid Drainers

All dimensions and weights are approximate. Use certified print for exact dimensions. Design and materials are subject to change without notice.